

# PROSORT MRT 90

The Model ProSort MRT is a sorter for medium-sized items. Product is transported on multiple narrow belts. Rollers pop up between the belts to transfer items at right angles to the sorter.

- Right Angle Transfer
- Two-Sided Transfer
- High Sort Rates
- Close Transfer Locations
- Flexible Sort Locations
- HyPower Distributed Cabling System

## 90° Medium Roller Transfer Conveyor

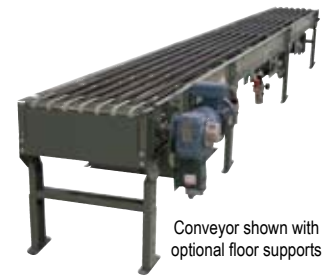

Conveyor shown with optional floor supports



Tail and Intermediate Section Length
24"
27"
30"
33"
36"
39"
42"
45"
48"
51"
54"
57"
60"
66"
72"
78"
84"
90"
96"
102"
108"
114"
120"

Between Rail "BR"	Overall Width "OAW"	Number of Belts
15"	18"	4
18"	21"	5
21"	24"	6
24"	27"	7
27"	30"	8

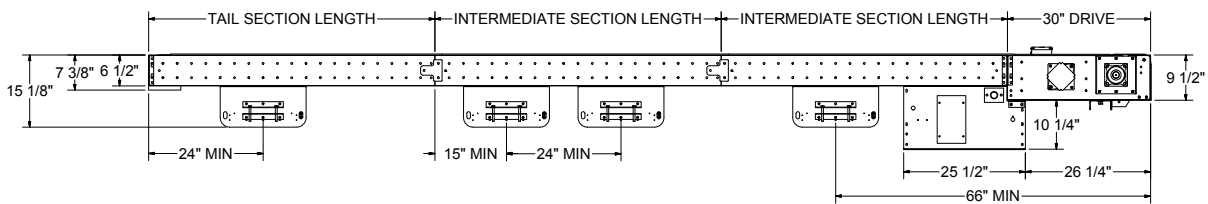
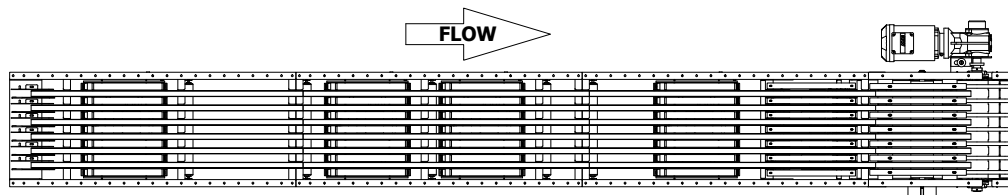
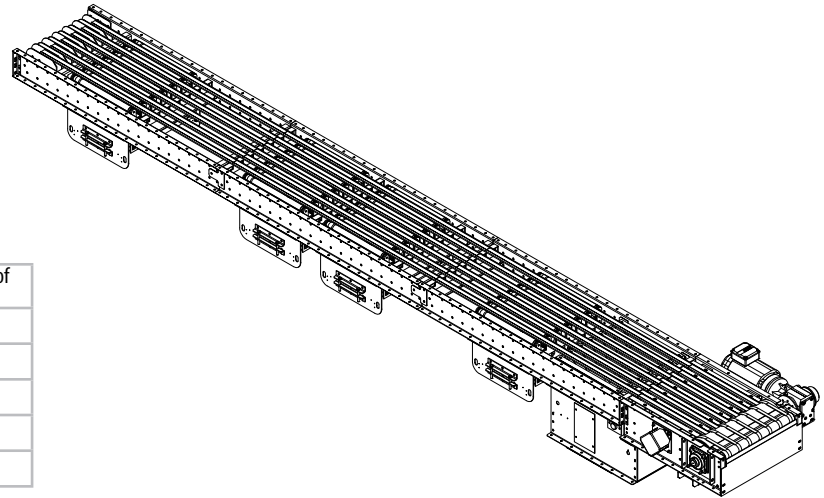

Conveyor Weights			
Overall Width "OAW"	Drive Weight (Lbs.)	Roller Transfer Weight (Lbs.)	Conveyor Weight Lbs. Per Foot
18"	185	102	13.6
21"	195	114	14.9
24"	205	126	16.1
27"	215	138	17.3
30"	225	150	18.5

Total Weight = Drive Weight + Roller Transfer Weight + (Conveyor Weight Per Foot x OAL)

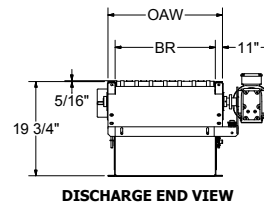

# STANDARD SPECIFICATIONS - CONVEYOR

# PROSORT MRT 90

**BELT-** Endless ARAMIDE Power Transmission Belt TF-102T

**BED-** UHMW wear strip spaced every 3 in., Mounted in 6 1/2 in. x 1 1/2 in. x 12 ga. powder painted formed steel channel frame bolted together with butt coupling.

**END DRIVE PULLEY-** 8 in. dia. with 1 3/8 in. dia. shaft at bearings, fully lagged with driven pop-up roller.

**SNUB PULLEY** - 4 in. dia. pulley with 1 in. dia. shaft at bearings. Drilled and tapped both ends for encoder.

**INFEDD IDLER PULLEY-** 4 in. dia. x 1 1/2 in. wide crowned sheave with precision bearings.

**PNEUMATIC TAKE-UP** - Take-up provides 14 in. of individual belt take-up. 25 PSI max on filter regulator. Need one pneumatic take-up for every 75 ft. of conveyor length.

**AIR FILTER, REGULATOR** - Supplied for main air line.

**RETURN ROLLERS** - 1.9" dia. galvanized tube with ABEC bearings. With cardboard tube inserts.

**BEARINGS-** Sealed, pre-lubricated, self-aligning ball bearings with eccentric lock collars. Pre-lubricated ball bearings in return rollers.

**DRIVE** - Shaft mounted gearmotor 3 HP- 230/460/575V -3 ph.- 60 hz. energy efficient, with an AC variable frequency controller.

**BELT SPEED-** Determined by application requirements including rate required, package size, and weight.

**TRACKING ENCODER** - Provided on snub pulley in drive section. Contact factory for encoder specification.

**CAPACITY-** Maximum unit package weight 75 lbs. Maximum distributed load determined by number of belts under product. (See chart.) 150 ft. maximum length. NOT TO EXCEED capacity in chart.

**FLOOR SUPPORTS**—Supplied as optional equipment.

Maximum Live Conveyor Load		
Overall Width "OAW"	Number of Belts	Maximum Conveyor Load (Lbs.)
18"	4	1200
21"	5	1500
24"	6	1800
27"	7	2100
30"	8	2400

# STANDARD SPECIFICATIONS - 90° MEDIUM ROLLER TRANSFER

**CAPACITY-** Maximum unit package weight of 75 lbs.

**PACKAGE SIZE-** minimum of 8 in. long x 6 in. wide – maximum length of 28 in.

**TRANSFER MECHANISM-** Series of 1 1/2 in. dia. x 17 in. long drive rollers with 3/32 in. lagging. Driven by 1 in. wide flexproof endless polyester belt.

**AIR CYLINDER-** 100 mm bore x 20 mm stroke guided table cylinder.

**AIR REQUIREMENTS-** Working pressure 60 P.S.I. Free air consumption at 60 P.S.I., .0556 cu. ft. per cycle.

**AIR VALVE** – 24-volt DC single solenoid 4 –way air valve.

**MOTOR-** 1/2 HP - 230/460 V–3 PH- 60 HZ Flange Mount Gearmotor.

**AC DRIVE** –1/2 HP – AC variable frequency controller.

**HYPOWER DISTRIBUTED CABLING SYSTEM** - Supplies distributed power to transfer motors. (See diagram.) Electrical Code: All motor controls and wiring shall conform to the National Electrical Code (Article 670 or other applicable articles) as published by the National Fire Protection Association and as approved by the American Standards Institute, Inc. Subject to local code and local customer acceptance.

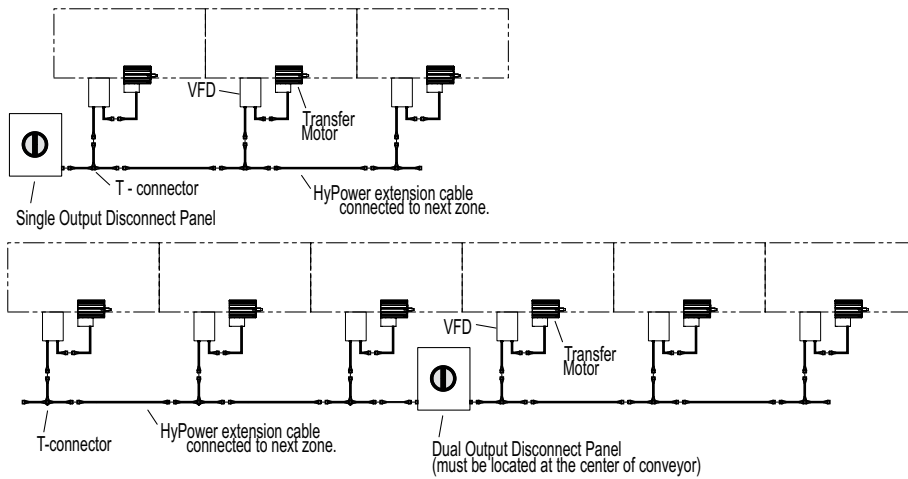

Close-up of Pop-Up Roller Transfer

DISCONNECT PANEL	230V	460V
	3 Ph. 60 Hz	3 Ph. 60 Hz
SINGLE OUTPUT	1-3 TRANSFERS	1-6 TRANSFERS
DUAL OUTPUT	4-6 TRANSFERS	7-12 TRANSFERS

NOTE: Sorters over 50 ft. long require a dual output disconnect panel.

# OPTIONAL EQUIPMENT

**FLOOR SUPPORTS-** MS Type floor supports are available with a wide range of adjustment. Specify top of belt elevation. One support required at every bed joint and ends of conveyor. Holes are in feet for lagging to floor. Knee braces supplied with MS-7 supports and above.

**GUARD RAILS-** Continuous adjustable channel, fixed channel or type A & B angle. NOTE: If product comes in contact with guard rails, products may not transfer.

**POLY-TIER SUPPORTS** – 36 in. to 120 in. support heights in 6 in. increments. Knee braces supplied.

**MOTORS-** Single phase, and other characteristics are available. For conveyor unit only.

**PROLOGIX CONTROL PACKAGE-** Provides complete controls for proper sorter operation. Contact factory for details.

**PLUG-N-GO WIRING** - Available with ProLogix Control Package.