

PROSORT 421 & 431 ELITE

High Speed Sortation Conveyor

The ProSort 421 is designed to sort products at a 22 degree angle where higher speeds are required and close divert centers are not so critical. The ProSort 431 is designed to sort products at a 30 degree angle where close divert centers are required. Products are transported on anodized aluminum slats where at a predetermined location, divert shoes move diagonally across the conveyor to push the product onto a take-away line. The ProSort 400 family of sorters are designed for high speed applications where product diverting needs to be both positive and gentle.

- 5 Widths Available
- Right or Left Hand Diverts Available
- High Sort Rates
- Anodized Aluminum Slats
- Adjustable MHS-Type Floor Supports Available



Conveyor shown with optional floor supports



*Note: Spur location is measured **from** the end of the section on both the 22 degree and the 30 degree diverts.

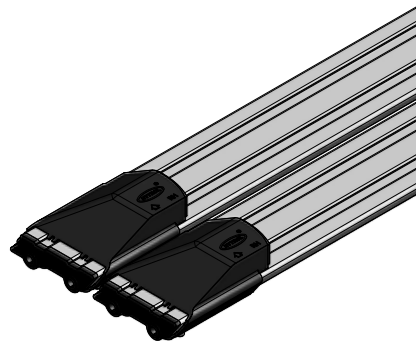

NOTE: SPUR WIDTH IS 6" WIDER THAN INDUCTION CONVEYOR

MINIMUM DISTANCE SAME AS MINIMUM LENGTH OF DIVERT SECTION

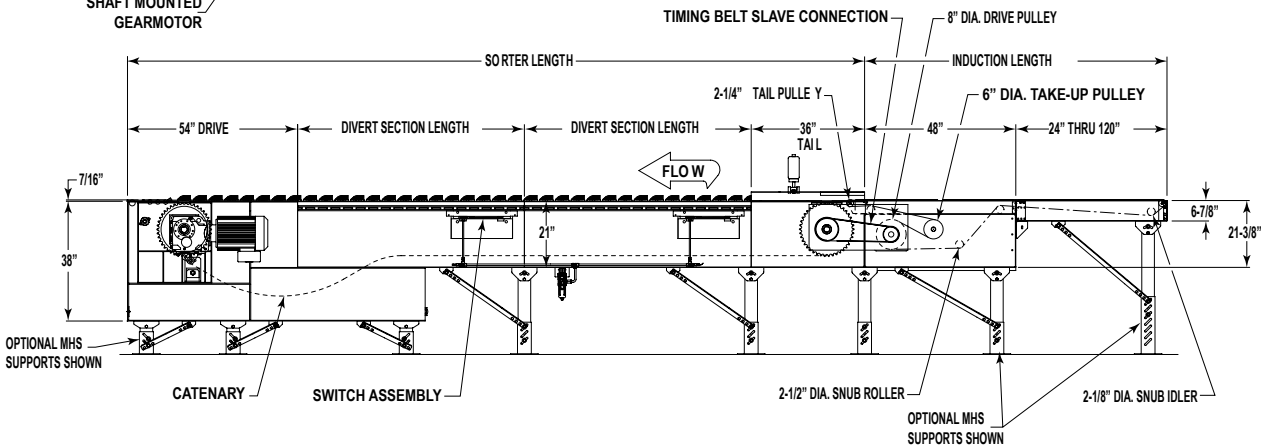
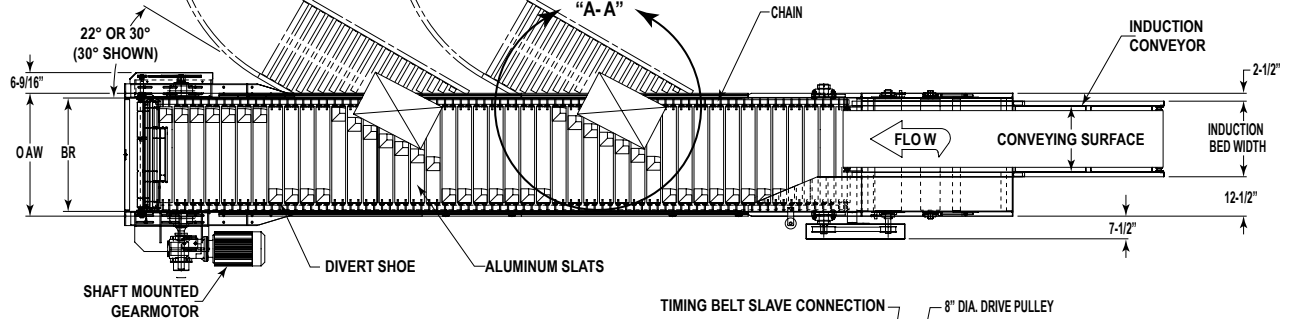
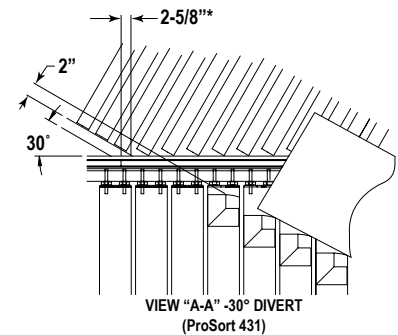
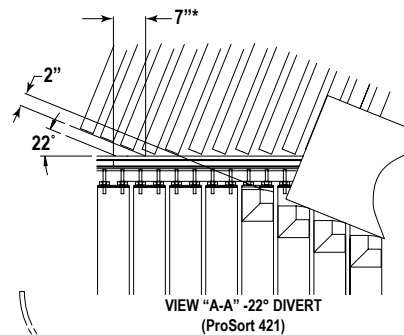

• STANDARD SPECIFICATIONS PROSORT 421 & 431 ELITE

INTERMEDIATE BED—21 in. deep x 1 ½ x ¾ in flange 10 ga. formed steel channel frame, powder painted.

TAIL BED—21 in. deep x 1 ½ x ¾ in flange 7 ga. formed steel channel frame, powder painted.

DRIVE/CATENARY BED—38 in. deep x 4 ga. formed steel channel frame, powder painted.

CARRYING CHAIN—Dual strands of No. 100 pre-lubricated o-ring roller chain with precision bearings and extended pins.

CHAIN LUBRICATOR—Installed at infeed end to lubricate carrying chains. Gravity feed with 24 volt DC on/off switch. Flow control valves to control the amount of oil allowed to flow to each of the brush applicators.

FLIGHTS—Anodized aluminum slat supported at each end by bushings and extended chain pins on 5 in. centers.

DIVERT SHOES—Low friction molded shoe with high friction pusher face. Steel guide pin for switching and ball bearing cam follower for diverting. Located on 5 in. centers.

SWITCH ASSEMBLY—Pneumatic or Electric operated high speed switch assembly mounted with rubber isolators for quietness and easily removable for maintenance.

AIR REQUIREMENTS—Free air consumption at 60 psi equals .0033 cu. ft. per divert only for pneumatic.

AIR VALVE—High speed 24 volt DC single solenoid 4-way air valve at each divert station only for pneumatic.

AIR FILTER, REGULATOR—Supplied for main air supply line with ½ in. NPT ports. Required working pressure of 60 psi only for pneumatic.

AIR PRESSURE SWITCH—Install in main air line near the last divert switch. Used to detect low air pressure and turn off drive only for pneumatic.

SMART PROXIMITY SWITCHES—24 volt DC inductive proximity switch. One at each divert. Requires maintained electrical signal for duration of each divert.

SAFETY SWITCHES—Switches located at infeed and discharge ends to detect stray divert shoes or internal jams. Additional switch supplied at 30 ft. intervals. Interrupts power to drive motor when these conditions are detected.

DRIVE—Shaft mounted gearmotor. Mounted at discharge end on the opposite side from the diverts. 230/460V-3Ph. 60Hz.

VARIABLE SPEED CONTROLLER—Provides smooth acceleration of drive motor and speed variations if necessary.

CONVEYING SPEED—Determined by application requirements. Up to 600 FPM on ProSort 421. Up to 350 FPM on ProSort 431.

PACKAGE SIZE—Minimum 9 in. long x 4 in. wide.

CAPACITY—Maximum load 50 lbs. per ft. Maximum product weight is 100 lbs.

INDUCTION CONVEYOR—Belt conveyor slave driven from sorter at same speed as sorter.

FLOOR SUPPORTS—Not supplied as standard. See optional equipment.

• STANDARD SPECIFICATIONS - INDUCTION CONVEYOR

BELT—Black, high-grip, longitudinal groove with high speed lacing, belt width is 6 in. less than overall width.

BED—12 ga. Galvanized slider pan mounted in 6 ½ in x 12 ga. Painted formed steel channel frame.

DRIVE—Slave driven at same speed as sorter via timing belt and bolted directly to infeed of sorter. Access holes designed into side plate for ease of pulley removal.

DRIVE PULLEY—8 in. dia. with 1 ¼ in. dia. shaft at bearings.

TAKE-UP PULLEY—6 in. dia. with 1 ¾ in. dia. shaft at bearings-Machine crowned.

TAIL PULLEY—2 ¼ in dia.-Machine crowned and easily removable.

TAKE-UP—Take-ups in drive provide 16 in. of belt take-up.

BEARINGS—Sealed, pre-lubricated, self-aligning, ball bearings on drive.

FLOOR SUPPORTS—Not supplied as standard. See optional equipment.

Sorter Conveying Surface Width	Sorter Between Rail Width "BR"	Sorter Overall Width "OAW"	Induction Bed Width "OAW"	Spur Width "OAW"	CONVEYOR SECTION									
					Drive (not including gearmotor)		Tail (not including induction belt)		Divert section with 22 degree diverter ProSort 421		Divert section with 30 degree diverter ProSort 431		Intermediate with no Divert	
					Length	Wt. (LBS)	Length	Wt. (LBS)	Length	Wt. (LBS)	Length	Wt. (LBS)	Length	Wt. (LBS)
15"	30"	33"	18"	24"	54"	1251	36"	511	78"	704	60"	545	9" to 120" on 3" increments	104
21"	36"	39"	24"	30"		1322		551	93"	879	72"	687		110
27"	42"	45"	30"	36"		1393		591	108"	1072	84"	838		116
33"	48"	51"	36"	42"		1464		631	123"	1278	96"	1000		122
39"	54"	57"	42"	48"		1536		671	138"	1498	108"	1182		128

All weights in catalog are conveyor weights only. Accessories, crating, etc., are not included.

GEARMOTOR WEIGHT	
HP	LBS
5	181
7.5	209
10	254
15	287
20	584
25	695
30	728
40	849

• OPTIONAL EQUIPMENT

FLOOR SUPPORTS—Adjustable MHS type w/ knee braces. Holes in feet for lagging to floor. Specify elevation. Vibration pads between channel and supports.

GUARD RAIL—6 1/2 in high solid side guards on switch side only.

FLIGHT TUBES—1 ½ in. dia. plated tubing supported at each end by bushings and extended chain pins on 2 ½ in. centers.

PROSORT LOGIX CONTROL PACKAGE—Provides complete controls for proper sorter operation. Consult factory for details.

