

# 190-LRSS Live Roller Straight Spur Conveyor

The Model 190-LRSS Live Roller Straight Spur is used in diverging or converging applications. It may be self-powered or can be slave driven from 190-ACC, LRC, or LRS conveyors.

- 12 Bed Widths
- Reversible
- Right or Left Hand Units Available
- Adjustable MS-Type Floor Supports Available



HYTROL CONVEYOR COMPANY, INC.

Between Rail Width	Overall Frame Width	"A"		"B"		WEIGHTS (Lbs.)	
		45°	30°	45°	30°	45°	30°
13"	16"	29"	38"	27"	36"	176	202
15"	18"	32"	41"	30"	39"	179	210
17"	20"	35"	47"	33"	45"	182	214
19"	22"	38"	50"	36"	48"	185	216
21"	24"	41"	53"	39"	51"	188	219
23"	26"	44"	56"	42"	54"	191	222
25"	28"	47"	62"	45"	60"	194	224
27"	30"	50"	65"	48"	63"	198	227
31"	34"	56"	74"	54"	72"	201	230
33"	36"	59"	77"	57"	75"	208	235
37"	40"	65"	86"	63"	84"	212	239
39"	42"	68"	89"	66"	87"	216	243

All weights in catalog are conveyor weights only. Accessories, crating, etc., are not included.

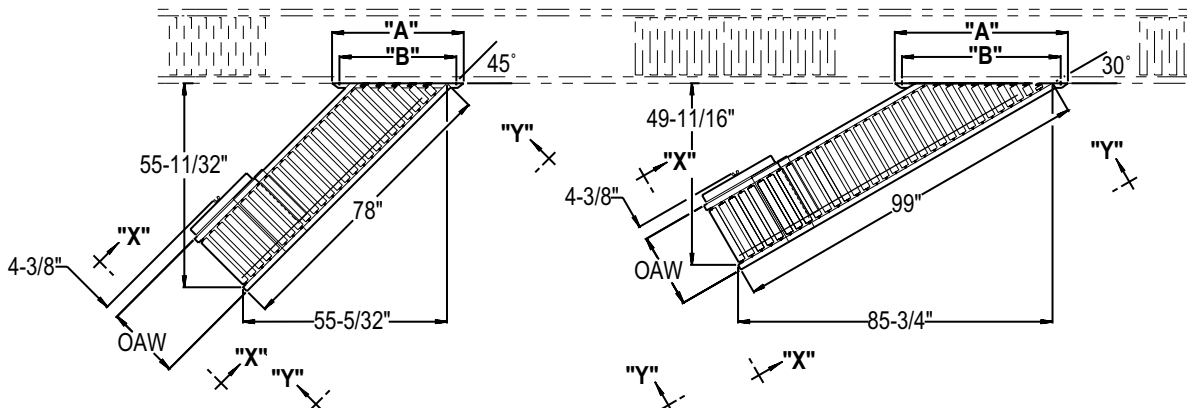
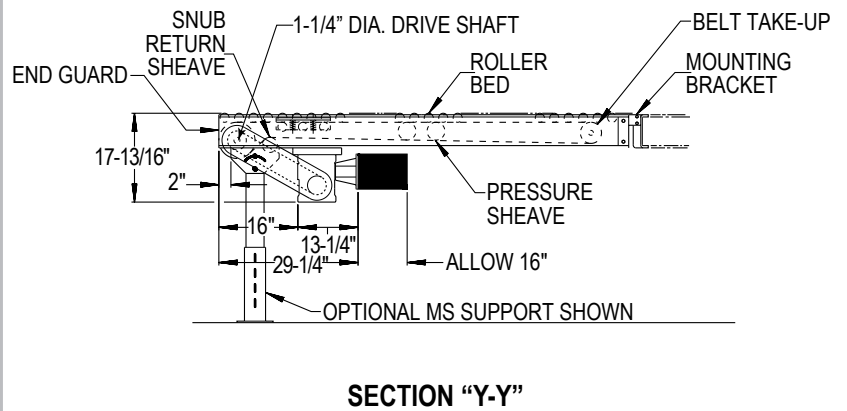
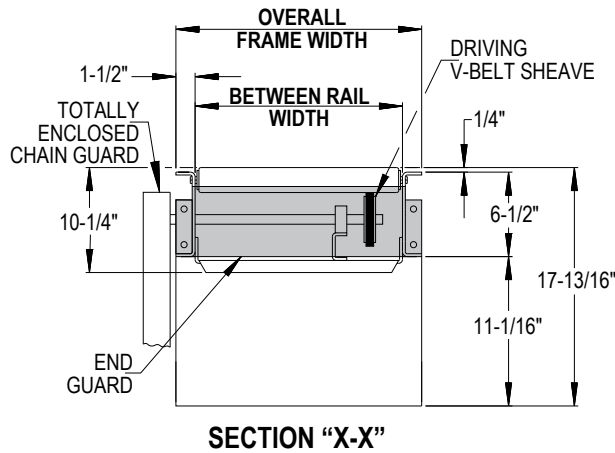

## • STANDARD SPECIFICATIONS

**BED**—Roller bed with 1.9 in. dia. roller x 16 ga. galvanized tube spaced every 3 in. Mounted in 6 ½ in. x 12 ga powder painted formed steel channel frame.

**END DRIVE**—Mounted underneath bed section.

**DRIVE BELT**—Endless B-section aramid core V-Belt drives each section of conveyor.

**PRESSURE SHEAVES**—2 ½ in. dia. with ¾ in. bore.

**SNUB RETURN SHEAVE**—3 ¼ in. dia. x ½ in. bore flat idler has seven position adjustment.

**TAKE-UP**—Take-ups provided to maintain proper V-belt tension. Includes 4 in. dia. x ¾ in. bore V type take-up sheave.

**BEARINGS**—Tread rollers have pre-lubricated ball bearings. Flange and pillow block bearings are sealed, pre-lubricated with eccentric lock collar.

**MOUNTING BRACKET**—Bracket is supplied to attach spur to side channels of 190-ACC, 190-ACZ, or 190-LR conveyors.

**BUTT COUPLINGS**—Standard for connecting 190-ACC, 190-LRC, 190-ACZ, or 190-LR conveyors.

**SPEED REDUCTION**—Sealed worm gear C-Face speed reducer. No. 50 roller chain to drive sheave.

**MOTOR**—½ HP—208/230/460/575V—3 PH. 60 Hz. Totally Enclosed.

**CONVEYING SPEED**—Constant 65 FPM.

**CAPACITY**—500 lbs. total distributed live load.

**FLOOR SUPPORTS**—Now supplied as optional equipment.

## • SPUR APPLICATIONS

Live Roller Spurs are used to transfer cartons, etc., onto and off of main conveyor lines. The illustrations below show the correct usage of Plows and Turning Wheels with Spurs in Diverging and Converging applications.

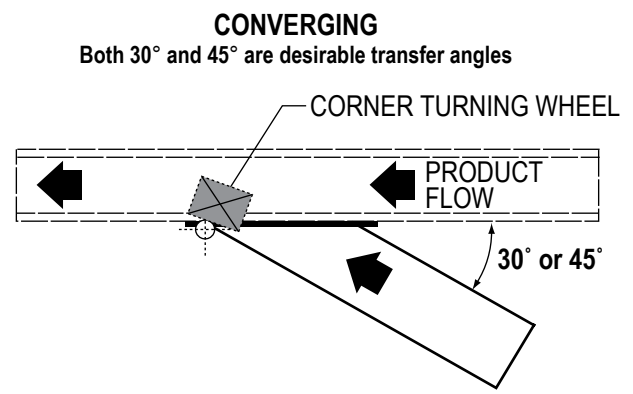
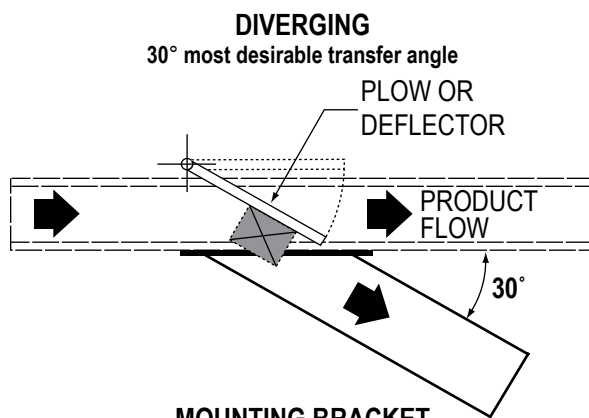

### MOUNTING BRACKET

The 190-LRSS is equipped with mounting brackets to attach unit to side channel of 190-ACC, 190-ACZ, or 190-LR.

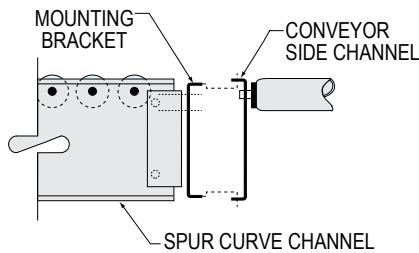

### SPUR FLOW (Specify)

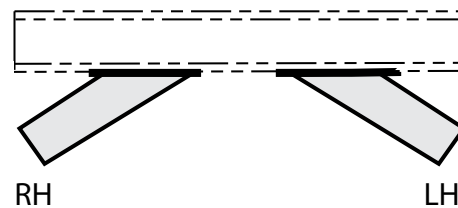

## • OPTIONAL EQUIPMENT

**FLOOR SUPPORTS**—MS Type floor supports are available with a wide range of adjustment. Specify top of belt or roller elevation. One support required at every bed joint and ends of conveyor. Holes in feet for lagging to floor. Knee braces recommended above MS-6 support.

**BED LENGTHS**—57 in., 63 in., 69 in., 75 in., 81 in., and 87 in. Drive not available on all lengths and widths. Contact factory.

**CONVEYING SPEED**—Other constant and variable speeds from 25 to 120 FPM. **NOTE:** Capacity affected with speed change.

**SHAFT MOUNTED DRIVE**—Motor reducer unit mounted on extended drive shaft. Can be mounted with standard sheave retainer for 10 ½ in. elevation (motor horizontal), or can be mounted with low elevation sheave retainer for 8 ¾ in. elevation (motor vertical). Mounting bracket and torque arm allows for multiple mounting positions. See chart page 47 (190-ACC) for speeds.

**SIDE MOUNTED DRIVE**—Motor-reducer unit mounted to side of conveyor. Minimum elevation—11 ½ in.

**O-RING DRIVE CHAIN**—With sealed in lubricant (Recommended for applications that do not permit regular lubrication).

**GUARD RAILS**—Adjustable Universal Channel Guard Rail—Fixed channel—Type A or B angle. See Accessory section. **Note:** If product comes in contact with guard rails, product flow will be affected.

**CEILING HANGERS**—¾ in. dia. x 8 ft. long unplated rods fully threaded. Other lengths and galvanized rods available.

**SLAVE DRIVEN**—Standard drive may be omitted and spur slave driven from 190-ACC, 190-ACZ, or 190-LR conveyors. (Specify by sketch, location of slave connection). Minimum elevation—11 in.

**MOTORS**—Energy efficient, single phase, brakemotor, other characteristics. 1 HP maximum.

**ELECTRICAL CONTROLS**—Non-reversing or reversible magnetic starters and push-button stations. AC variable frequency drive.