

199-CRRC

The 199-CRRC is a chain driven live roller curve that aids in alignment of packages, cartons, etc., through 30°, 45°, 60° and 90° curves. Can be used in conveying oily parts.

Chain Driven Live Roller Curve Conveyor

- 11 Bed Widths
- Reversible
- Tapered Tread Rollers
- Can Be Slave-driven from 199-CRR
- Adjustable MSN-Type Floor Supports Available

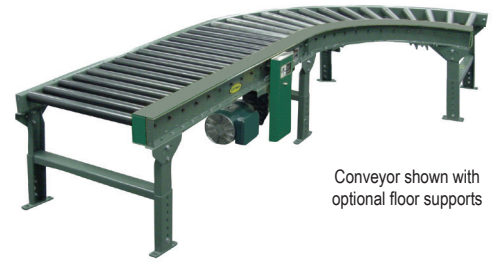

Conveyor shown with optional floor supports

Conveying Surface	Between Rail Width	Overall Frame Width	"R"	Number of Rollers*				WEIGHTS (Lbs.)			
				90°	60°	45°	30°	90°	60°	45°	30°
12 1/4"	15"	18"	32 1/2"	14T	10T	6T	4T	390	312	297	282
14 1/4"	17"	20"						400	320	305	290
16 1/4"	19"	22"						410	328	313	298
18 1/4"	21"	24"						420	336	321	306
20 1/4"	23"	26"						430	344	329	314
22 1/4"	25"	28"						440	352	337	322
24 1/4"	27"	30"	48"	20T	16T	10T	6T	450	360	345	330
28 1/4"	31"	34"						480	390	375	365
30 1/4"	33"	36"						560	398	383	373
34 1/4"	37"	40"						530	414	399	389
36 1/4"	39"	42"						540	432	407	397

All weights in catalog are conveyor weights only. Accessories, crating, etc., are not included.

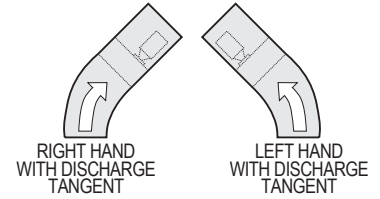

NOTE: SPECIFY RH OR LH CURVE

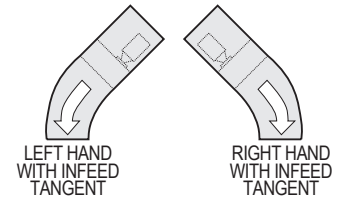

NOTE: SPECIFY RH OR LH CURVE

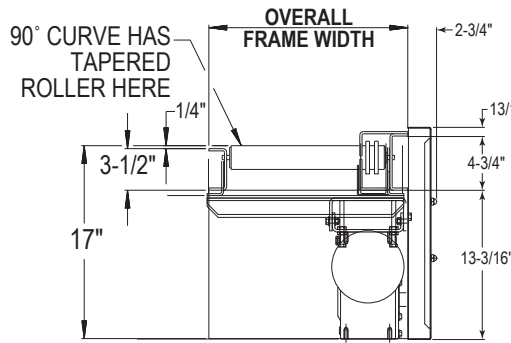
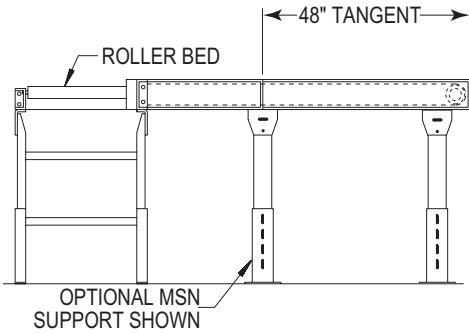

SECTION X-X

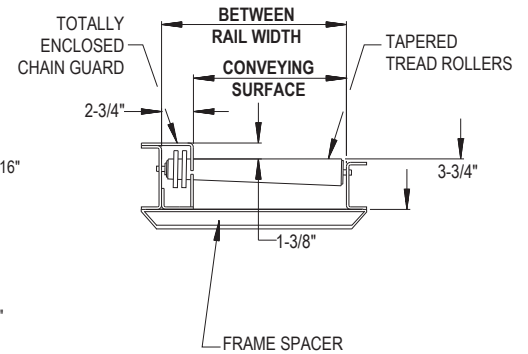

SECTION Y-Y

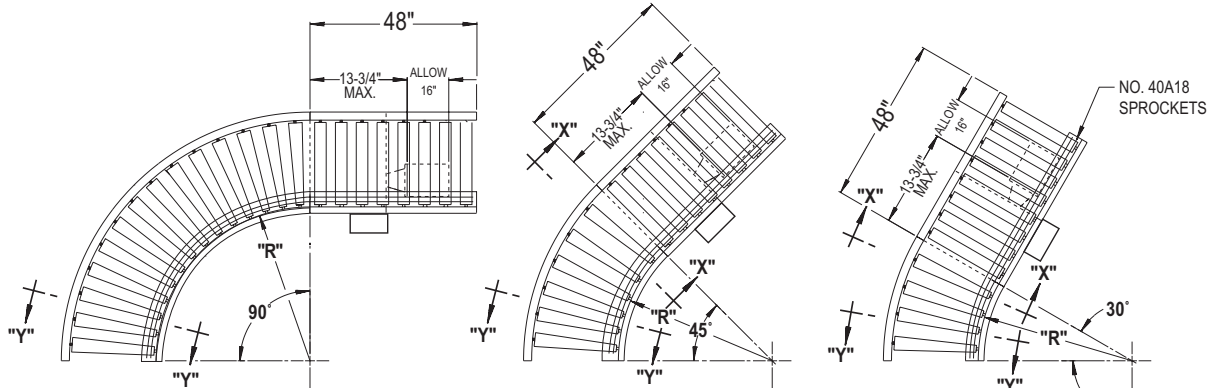

• STANDARD SPECIFICATIONS

BED—Roller bed with 2 ½ in. dia. tapered to 1 1¼ in. dia. x 14 ga. unplated rollers mounted in 10 ga. powder painted formed steel channel frame.

CENTER DRIVE—Located on 4'-0" long straight section.

ROLLER CHAIN—No. 40 circular roller-to-roller chain.

MOTOR DRIVE CHAIN—No. 60 chain.

CHAIN GUARD—Mounted to top of channel frame to totally enclose drive chain.

BEARINGS—Sealed, pre-lubricated ball bearings.

BUTT COUPLINGS—Standard for connecting to 199-CRR.

SPEED REDUCTION—Sealed worm gear C-Face speed reducer.

MOTOR—½ HP—208/230/460/575V—3 Ph. 60 Hz. Totally Enclosed C-Face.

CONVEYING SPEED—Constant 35 FPM.

CAPACITY—850 lbs. total distributed live load.

FLOOR SUPPORTS—Now supplied as optional equipment.

• OPTIONAL EQUIPMENT

FLOOR SUPPORTS—MSN Type floor supports are available with a wide range of adjustment. Specify top of belt or roller elevation. One support required at every bed joint and ends of conveyor. Holes in feet for lagging to floor. Knee braces recommended above MSN-6 support.

CONVEYING SPEED—Other constant and variable speeds. **NOTE:** Capacity affected with speed change.

SHAFT MOUNTED DRIVE—Requires shaft mounted gearmotor. Minimum elevation top of rollers 6 in.

O-RING DRIVE CHAIN—With sealed in lubricant (Recommended for applications that do not permit regular lubrication).

ROLLERS SET LOW—Tread rollers mounted in 4 ¾ in. x 10 ga. formed steel channel frame to form 1 in. high guard rails.

GUARD RAILS—Adjustable Universal Channel Guard Rail (both sides), fixed channel (both sides) or angle (one side). See Accessory section

POLY-TIER SUPPORTS—36 in. to 120 in. support heights in 6 in. increments. Knee braces required.

CEILING HANGERS—½ in. dia. x 8 ft. long unplated steel rods. Other lengths and galvanized rods available.

MOTORS—Energy efficient, single phase, brakemotor, other characteristics. 1 HP maximum.

ELECTRICAL CONTROLS—Non-reversing or reversible magnetic starters and push-button stations. AC variable frequency drive.