

SYSTEMS ACCESSORIES

O-RING TRANSFER (BR TYPE)

O-Ring Transfers are used to move products at right angles to adjacent or parallel conveyor lines. An air bag lifts the transfer mechanism while powered O-Rings transfer the product. Linear bearings are used to guide transfer as it is raised and lowered. Can be used with Models 138 and 190-NSP/NSPEZ line shaft conveyors.

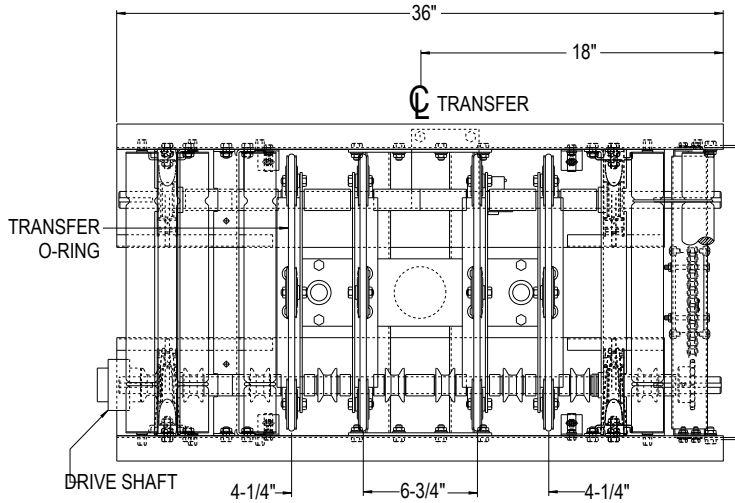
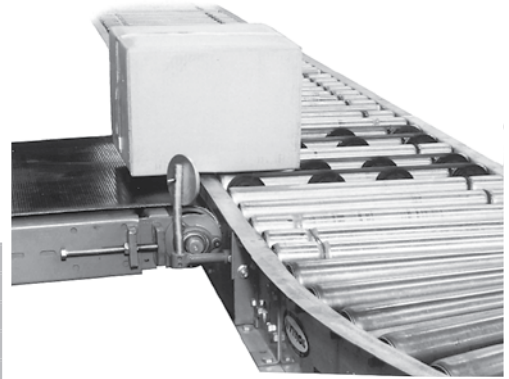

190-NSP	
OAW	BR
16"	13"
18"	15"
20"	17"
22"	19"
24"	21"
26"	23"
28"	25"
30"	27"
34"	31"
36"	33"
40"	37"
42"	39"

138-NSP	
OAW	BR
15"	13"
18"	16"
24"	22"

Note: No accumulation in transfer section

¼ HP per transfer must be included in conveyor HP requirement.

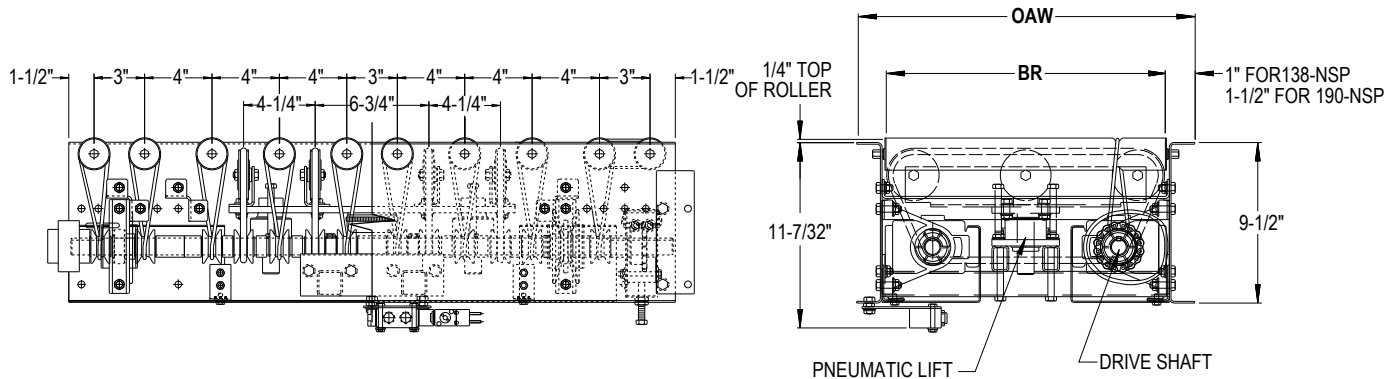

• STANDARD SPECIFICATIONS

CAPACITY—75 lbs. maximum unit load.

TRANSFER O-RING— $\frac{3}{8}$ " dia. polyurethane o-ring.

TRANSFER SPEED—Not to exceed speed of conveyor.

DRIVE—Transfer is driven from line shaft of conveyor.. Maximum of 4 transfers per drive.

MOUNTING—Mounted in 36 in. long section of 138-NSP, 190-NSP, 138-NSPEZ, 190-NSPEZ with 3 and 4 in. roller centers.

ELECTRICAL CONTROLS—Not furnished as standard equipment.

PNEUMATICS—Air bag (controlled by single solenoid valve) lifts transfer. Requires maintained electrical signal of 115V—1 Ph. 60 Hz. from photo cell, limit switch, etc. (not supplied). Transfer will stay in raised position until signal is broken. Current consumption is .09 amps holding.

AIR REQUIREMENTS—Minimum pressure 60 P.S.I., maximum 100 P.S.I. Free air consumption at 60 P.S.I., .033 cu. ft. per cycle.**NOTE:** To eliminate contaminants in air supply line, a filter-regulator should be installed prior to the air valve (not supplied as standard).