

# B

## Portable Folding Cleated Conveyor

Ideal for stacking, loading, and unloading. Cleats permit use at steeper inclines up to 45°. Complete with portable base.

- Folding Bed
- Roughtop Belt with Hardwood Cleats
- Rugged Steel Frame
- Self-powered Raising Device
- Reversible



SIZE TO ORDER	Overall Length "A"	Angle of Incline	"L"	"H"	"E"	"C"	"B" Folded Length	Weights (Lbs.)
10'	10'-9"	0°	10'-11"	1'-4"	5'-1"	44"	5'-10"	545
		25°	9'-11"	5'-7"	4'-1"			
		30°	9'-4"	6'-5"	3'-6"			
		45°	7'-9"	8'-6"	1'-11"			
12'	12'-9"	0°	12'-11"	1'-4"	6'-1"	68"	6'-10"	590
		25°	11'-8"	6'-6"	4'-10"			
		30°	11'-1"	7'-5"	4'-3"			
		45°	9'-2"	10'-0"	2'-4"			
14'	14'-9"	0°	14'-11"	1'-4"	7'-1"	80"	7'-10"	650
		25°	13'-6"	7'-4"	5'-8"			
		30°	12'-10"	8'-5"	5'-0"			
		45°	10'-7"	11'-6"	2'-9"			
16'	16'-9"	0°	16'-11"	1'-4"	8'-1"	92"	8'-10"	695
		25°	15'-4"	8'-2"	6'-6"			
		30°	14'-7"	9'-5"	5'-9"			
		45°	12'-0"	13'-0"	3'-2"			

All weights in catalog are conveyor weights only. Accessories, crating, etc., are not included.

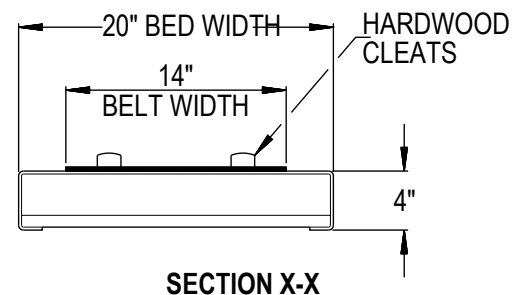
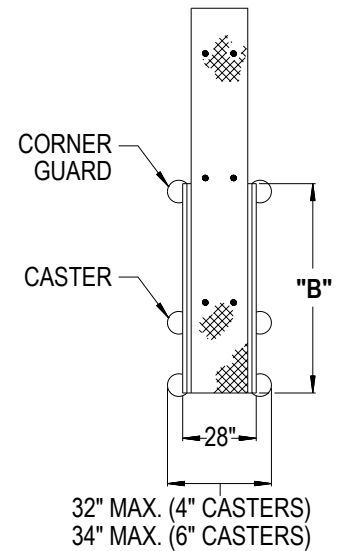
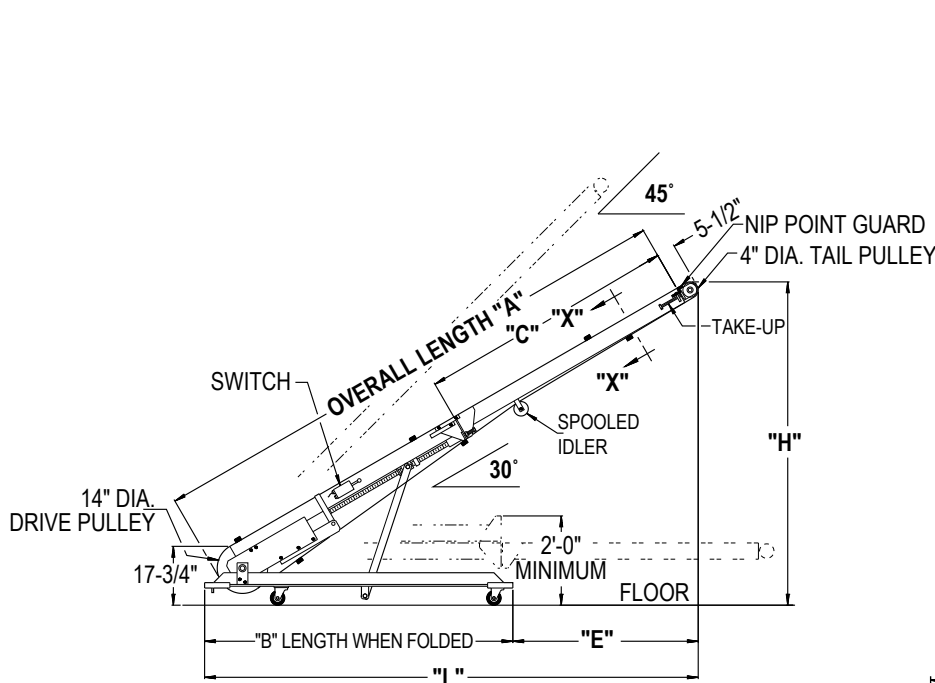

## • STANDARD SPECIFICATIONS

**BELT**—14 in. wide Black Trackmate 120 Roughtop with PVC cover. Clipper lacing.

**CLEATS**—Two 1 ½ in. dia. x 1 in. high hardwood cleats, fastened to belt with 5/16 in. elevator bolts spaced every 60 in.

**BED**—4 in. deep x 20 in. wide x 12 ga. powder painted formed steel slider bed. Bed is hinged for storage purposes (see drawing).

**HINGES**—To fold bed to shorter length for storage. Screw adjustment insures alignment of bed. Exclusive link (breathing feature) prevents damage of belt.

**INCLINE**—Adjustable with conveyor motor powered screw raising device (see chart for angles). Safety nut prevents rapid release of bed in case of overloading.

**BASE**—Welded steel base (see drawing for dimensions).

**CASTERS**—6 in. dia. steel swivel casters with 2 Floor Locks. Corner guards.

**DRIVE PULLEY**—14 in. dia. with 1 in. dia. removable shaft. Crowned and fully lagged.

**TAIL PULLEY**—4 in. dia. with 1 in. dia. shaft at bearings, crowned.

**RETURN IDLER**—4 in. dia. spooled idler to provide clearance for cleats. Pre-lubricated ball bearings.

**TAKE-UP**—Take-ups provided at tail pulley. Provides 4 in. of belt take-up.

**BEARINGS**—Sealed, pre-lubricated, self-aligning, ball bearings on tail pulley. Re-lube roller bearings on drive pulley.

**SPEED REDUCTION**—Sealed worm gear speed reducer driven by V-belt. No. 50 roller chain to drive pulley.

**MOTOR**—1 HP -115/230V-1 Ph. 60 Hz. Totally Enclosed. Wired for 115 volt.

**ELECTRICAL CONTROLS**—Reversing drum switch with 20 ft. power cord and plug.

**BELT SPEED**—Constant 65 FPM.

**CAPACITY**—300 lbs. total distributed load, 150 lbs. unit load at 65 FPM.

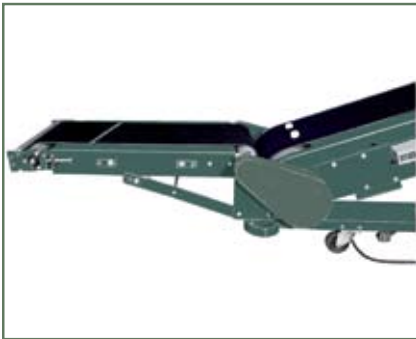

LOWER POWERED FEEDER



TROUGHING ATTACHMENT WITH HOPPER



SELF-POWERED RAISING DEVICE

## • OPTIONAL EQUIPMENT

**RUBBER CASTERS**—4 in. dia. rubber swivel casters in place of steel casters.

**FLOOR LOCKS**—Two foot operated toggle floor locks mounted on one side of conveyor base to prevent unit from moving when in operation.

**GRAVITY CONVEYOR BRACKET**—Adjustable bar for connecting wheel or roller gravity conveyor (discharge only).

**LOWER GRAVITY FEEDER**—2 ft. long x 18 in. wide (1 ½ SW-18-36) includes adjustable tubular support and gravity conveyor bracket.

**UPPER GRAVITY FEEDER**—2 ft. long x 18 in. wide (3 SW-18-18) includes adjustable tubular support and gravity conveyor bracket.

**LOWER POWERED FEEDER**—Chain type driven from drive pulley. 43 in. long belt feeder section includes adjustable tubular support and gravity conveyor bracket.

**GUARD RAILS**—Channel type, adjustable vertically (specify fixed horizontal width). Not foldable with guard rails.

**TROUGHING ATTACHMENT**—Flat steel supports under belt form trough for handling loose material. Hopper available. Not foldable with troughing attachment.

**REMOTE SWITCH CONTROL**—Rod running length of conveyor to operate reverse drum switch from both ends. Switch regularly furnished on right side (when standing at drive pulley and looking up toward tail pulley).

**MOTORS**—2 HP 230/1/60.