

General

Flow-Turn Chain Driven Power Belt Curves especially design to convey small products safe and reliable in an industrial environment such as in the material handling industry, manufacturing industry, distribution centers or airports.

- Cylindric End Rollers for minimal even Gaps between Conveyors
- Simple, Efficient and Reliable Design
- Rugged Steel Construction
- Low Maintenance Requirements
- Low Noise Operation

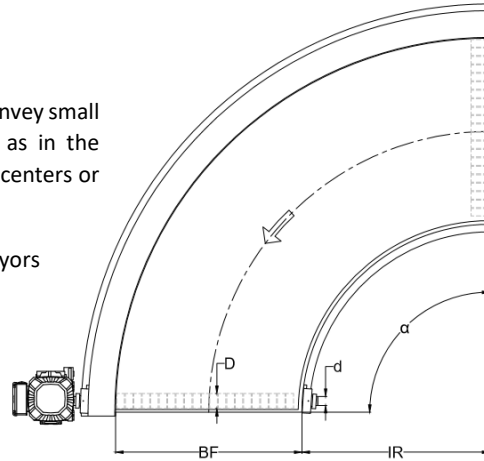

Dimensions

- Minimum Inside Radius IR(min): 24"
- Maximum Between Frame Dimension BF(max): 65"
- Frame Height H: 8.5"
- End Roller Diameter D: 4"
- Shaft Diameter d: 1-7/16"
- Max. Conveyor Angle α : 270°

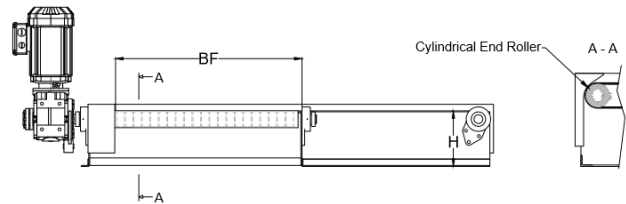

Technical Data

- Speed up to 600 fpm
- Load 40 lbs./ft.
- Permissible ambient temperature range: -5°F to 130°F
- Active Chain Drive system with loose belt technology to minimize belt wear.

Options

- Removable Inside Frame for Endless Belts
- Stainless Steel Frame
- H-Supports
- Ceiling Hangers
- Product Guards
- Under Guards
- Slider Bed Relief Rollers
- Hand Rails
- Motor at Inside Radius
- Drive via Timing Belt
- Beam Array Sensor Mount

STANDARDS

- DIN EN 619:2011-02 (Continuous handling equipment and systems – Safety and EMC requirements for equipment for mechanical handling of unit loads)
- DIN EN ISO 340:2013-01 (Conveyor Belts – Laboratory scale flammability characteristics – Requirements and test method)
- Machinery Directive 2009/127/EC
- RoHS 2011/65/EU (Restriction of certain Hazardous Substances)
- CE compliant

General

Flow-Turn Chain Driven Power Belt Curves especially design to convey small products safe and reliable in an industrial environment such as in the material handling industry, manufacturing industry, distribution centers or airports.

- Cylindric End Rollers for minimal even Gabs between Conveyors
- Simple, Efficient and Reliable Design
- Rugged Steel Construction
- Low Maintenance Requirements
- Low Noise Operation

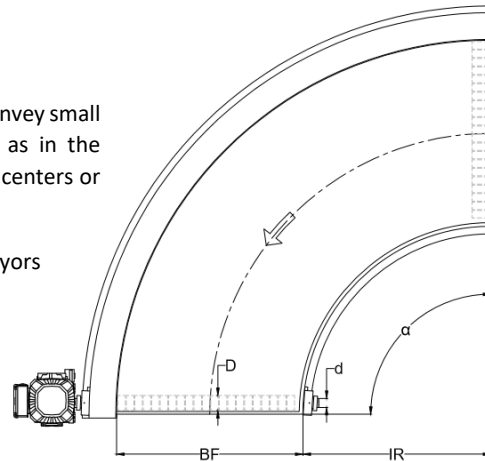

Dimensions

- Minimum Inside Radius IR(min): 610 mm
- Maximum Between Frame Dimension BF(max): 1650 mm
- Frame Height H: 215 mm
- End Roller Diameter D: 100 mm
- Shaft Diameter d: 35 mm
- Max. Conveyor Angle α : 270°

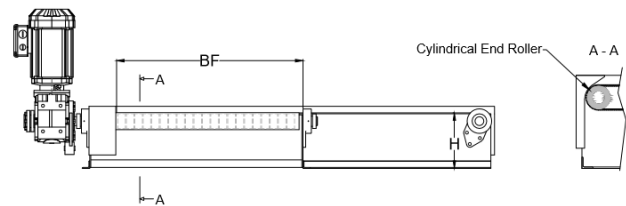

Technical Data

- Speed up to 3.0 m/sec.
- Load 60 kg/m
- Permissible ambient temperature range: -15°C to 55°C
- Active Chain Drive system with loose belt technology to minimize belt wear.

Options

- Removable Inside Frame for Endless Belts
- Stainless Steel Frame
- H-Supports
- Ceiling Hangers
- Product Guards
- Under Guards
- Slider Bed Relief Rollers
- Hand Rails
- Motor at Inside Radius
- Drive via Timing Belt
- Beam Array Sensor Mount

STANDARDS

- DIN EN 619:2011-02 (Continuous handling equipment and systems – Safety and EMC requirements for equipment for mechanical handling of unit loads)
- DIN EN ISO 340:2013-01 (Conveyor Belts – Laboratory scale flammability characteristics – Requirements and test method)
- Machinery Directive 2009/127/EC
- RoHS 2011/65/EU (Restriction of certain Hazardous Substances)
- CE compliant